

**Modular Cooking Range Line
 thermaline 80 - 2x7 lt Wells Freestanding
 Electric Deep Fat Fryer, 1 Side,
 Backsplash, H=800**

ITEM # _____

MODEL # _____

NAME # _____

SIS # _____

AIA # _____



588298 (MAFBFBDDAO) 5+5lt electric Deep Fat Fryer, one-side operated with backsplash

Short Form Specification

Item No. _____

Unit constructed according to DIN 18860_2 with 20 mm drop nose top and 70 mm recessed plinth. Internal frame for heavy duty sturdiness in stainless steel. 2 mm top in 1.4301 (AISI 304). Flat surface construction, easily cleanable. THERMODUL connection system enables seamless worktop when units are connected and avoids soil penetrating. Appliance designed to deep fry meat, fish and vegetables (french fries). Direct oil heating system with electric elements inside the frying well. Electronic sensor for precise oil temperature control. Reduced power setting to melt solid fat. Oil can be easily drained via a ball-valve. All-round basin raised edges to protect against soil infiltration. Large overflow stamped area around the well. Overheat protection switches off the supply in case of overheating. Standby function saves energy and quickly recovers maximum power. Metal knobs with embedded hygienic silicon "soft" grip enable easier handling and cleaning. IPX5 water resistant certification.
 Configuration: Freestanding, one-side operated with backsplash.

Main Features

- All major components may be easily accessed from the front.
- THERMODUL connection system creates a seamless work top when units are connected to each other thus avoiding soil penetrating vital components and facilitating the removal of units in case of replacement or service.
- Metal knobs with embedded hygienic "soft-touch" grip for easier handling and cleaning. The special design of the controls prevents infiltration of liquids or soil into vital components.
- Overheat protection: the temperature sensor switches off the supply in case of overheating.
- Large visible digital display manufactured in tempered glass to resist heat and chemicals, showing temperatures or power settings. The display also shows on/off status of the appliance and on/off status of the heating elements.
- Raised edge all around the well to protect from infiltration of dirt from worktop.
- Large overflow stamped area, located around the well.
- Direct oil heating system with electric elements inside the frying well.
- Reduced power setting to melt solid fat.
- Oil level mark for MAX/MIN filling.
- Designed for deep fat frying of meat, fish, specialities and vegetable (french fries, chips).
- Oil can be drained off via a ball-valve with a lock to prevent unintentional opening. When opened, the ball valve provides a full cross-section opening to easily clean the drainage system.
- Electronic sensor for precise oil temperature control.

Construction

- 2 mm top in 1.4301 (AISI 304).
- Unit constructed according to DIN 18860_2 with 20 mm drop nose top and 70 mm recessed plinth.
- Flat surface construction with minimal hidden areas to easily clean all surfaces
- IPX5 water resistance certification.
- Internal frame for heavy duty sturdiness in stainless steel.

Sustainability



- Standby function for energy saving and fast recovery of maximum power.
- This model is compliant with Swiss Energy Efficiency Ordinance (730.02).

APPROVAL: _____

Included Accessories

- 1 of Pair of baskets for 2x5lt deep fat fryer PNC 913035
- 2 of Filter for 2x5 and 7lt deep fat fryer oil collection basin PNC 913154

Optional Accessories

- Connecting rail kit for appliances with backsplash, 800mm PNC 912497
- Stainless steel front kicking strip, 400mm width PNC 912594
- Stainless steel side kicking strips left and right, against the wall, 800mm width PNC 912622
- Stainless steel side kicking strips left and right, back-to-back, 1610mm width PNC 912625
- Stainless steel plinth, against wall, 400mm width PNC 912802
- Connecting rail kit for appliances with backsplash: modular 80 (on the left), ProThermetic tilting (on the right), ProThermetic stationary (on the left) to ProThermetic tilting (on the right) PNC 912977
- Connecting rail kit for appliances with backsplash: modular 80 (on the right), ProThermetic tilting (on the left), ProThermetic stationary (on the right) to ProThermetic tilting (on the left) PNC 912978
- Back panel, 400x800mm, for units with backsplash PNC 913022
- Stainless steel panel, 800x800mm, against wall, left side PNC 913094
- Stainless steel panel, 800x800mm, flush-fitting, against wall, right side PNC 913098
- Endrail kit, flush-fitting, with backsplash, left PNC 913113
- Endrail kit, flush-fitting, with backsplash, right PNC 913114
- Endrail kit (12.5mm) for thermaline 80 units with backsplash, left PNC 913204
- Endrail kit (12.5mm) for thermaline 80 units with backsplash, right PNC 913205
- Insert profile D=800mm PNC 913230
- Energy optimizer kit 18A - factory fitted PNC 913245
- Side reinforced panel only in combination with side shelf for against the wall installations, left PNC 913264
- Side reinforced panel only in combination with side shelf, for against the wall installations, right PNC 913266
- Filter W=400mm PNC 913663
- Stainless steel dividing panel, 800x800mm, (it should only be used between Electrolux Professional thermaline Modular 80 and thermaline C80) PNC 913669
- Electric mains switch 25A 4mm² NM for modular H800 electric units (factory fitted) PNC 913676

- Stainless steel side panel, 800x800mm, flush-fitting (it should only be used against the wall, against a niche and in between Electrolux Professional thermaline and ProThermetic appliances and external appliances - provided that these have at least the same dimensions) PNC 913685

Front

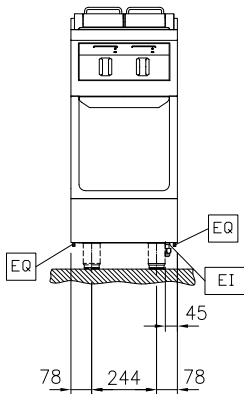

Side

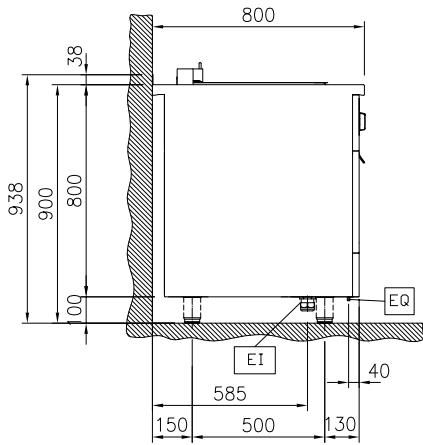

EI = Electrical inlet (power)
 EQ = Equipotential screw

Top

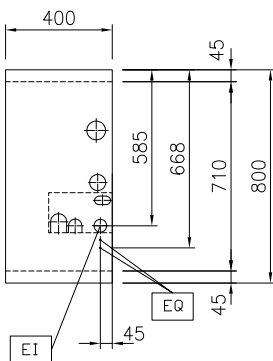
Electric

Supply voltage: 400 V/3N ph/50/60 Hz
 Total Watts: 12 kW

Key Information:

Number of wells: 2
 Usable well dimensions (width): 140 mm
 Usable well dimensions (height): 230 mm
 Usable well dimensions (depth): 345 mm
 Well capacity: 4 lt MIN; 5 lt MAX
 Thermostat Range: 100 °C MIN; 180 °C MAX
 External dimensions, Width: 400 mm
 External dimensions, Depth: 800 mm
 External dimensions, Height: 800 mm
 Net weight: 55 kg
 Configuration: On Base; One-Side Operated

Sustainability

Current consumption: 17.3 Amps